

**INSTALLATION INSTRUCTIONS**

Original Issue Date: 3/94

Model: 30-275 kW Fast-Response™ I Generator Sets

Market: Industrial

Subject: Split Activator Service Kits 226655, 226673, and 226674

**Introduction**

Generator Models	Kit
30 kW	226673
40-100 kW	226655
125-275 kW	226674

The service kits are used on the 30-275 kW Fast-Response™ I generator sets and are designed to replace the standard one-piece FR™ activator with a new split activator. Although the function of the FR™ activator remains unchanged, the components of the activator are now distributed between the rotating photo transistor board and the SCR (silicon-controlled rectifier) assembly.

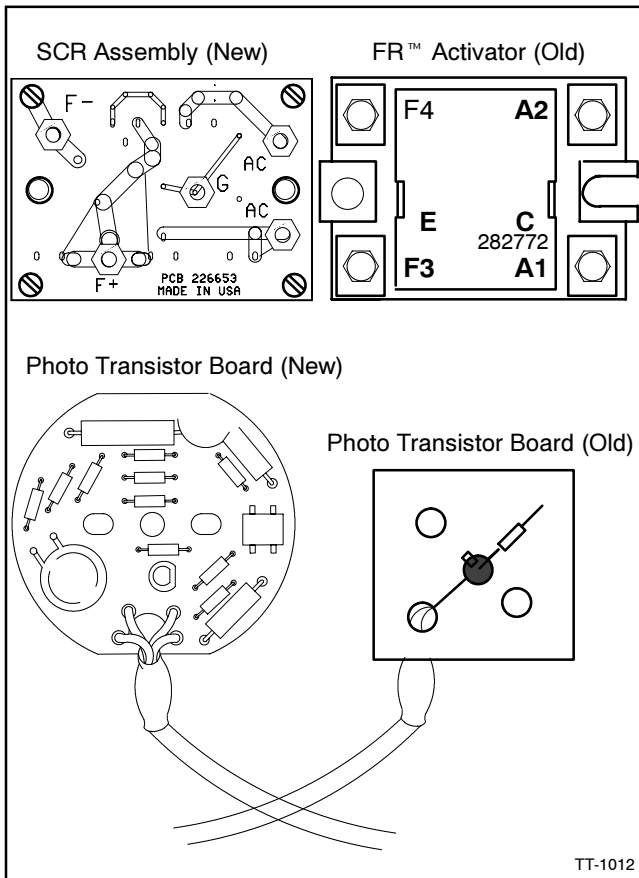
The SCR assembly occupies the same position as the old FR™ activator and still controls current flow to the generator field. However, the control circuit for the SCR is now located on the shaft-mounted photo transistor board. Refer to Figure 1 for a comparison between the one-piece and split FR™ activators. Observe the safety precautions listed with the text when installing the split FR™ activator kit.

**Note:** The FR™ activator shown in Figure 1 is part number 282772. Earlier versions of this component had different terminal designations. This subject is further addressed in the installation procedure.

Read the entire installation procedure and compare the kit parts with the parts list at the end of this publication before beginning installation. Perform the steps in the order shown.

**Safety Precautions**

Observe the following safety precautions while installing the kit.



**Figure 1** FR™ Activator Comparison

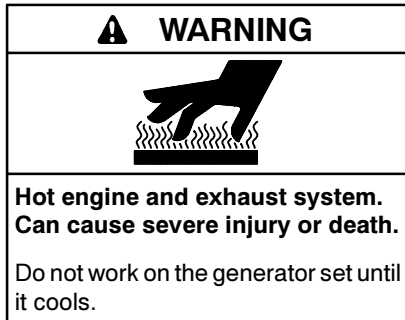
**WARNING**



**Accidental starting.**  
Can cause severe injury or death.

Disconnect the battery cables before working on the generator set. Remove the negative (-) lead first when disconnecting the battery. Reconnect the negative (-) lead last when reconnecting the battery.

**Disabling the generator set. Accidental starting can cause severe injury or death.** Before working on the generator set or connected equipment, disable the generator set as follows: (1) Move the generator set master switch to the OFF position. (2) Disconnect the power to the battery charger. (3) Remove the battery cables, negative (-) lead first. Reconnect the negative (-) lead last when reconnecting the battery. Follow these precautions to prevent starting of the generator set by an automatic transfer switch, remote start/stop switch, or engine start command from a remote computer.



**Servicing the generator. Hot parts can cause severe injury or death.** Avoid touching the generator set field or exciter armature. When shorted, the generator set field and exciter armature become hot enough to cause severe burns.

**Note:** Installation of the split activator service kit may require removal of the generator end bracket. If generator end bracket disassembly is required, refer to Fast-Response™ I service manual, part no. TP-5044 for procedure. Larger units should have sufficient clearance to allow installation of the kit without generator rotor disassembly.

## Installation Procedure

### 30 kW Installation

1. Place generator set master switch in the OFF position.
2. Disconnect power to battery charger, if equipped.
3. Disconnect generator set engine starting battery(ies), negative (-) lead first.
4. Remove generator end cover and junction box doors.
5. Remove mounting hardware connecting junction box to skid. Remove junction box and controller as a unit to provide enough clearance to provide end bracket removal. Disconnect and tag wiring as necessary to accomplish this step.
6. Disconnect leads 3B and 5B from LED board. Remove four screws to disconnect LED board from

end bracket. Screws will be reused. Discard LED board.

7. Disconnect leads 2 (black), 16 (white), and 24 (red) from speed sensor.
8. Remove screws securing photo transistor board. Remove photo transistor board from rotor assembly by cutting leads. Discard old photo transistor board and screws.
9. Remove screws securing end bracket to stator assembly and remove end bracket. Use a rubber mallet or puller as necessary to remove end bracket from rotor shaft bearing.
10. Remove speed sensor and bracket assembly by removing two screws. Remove speed sensor from bracket by removing two screws. Speed sensor will be reused. Discard mounting hardware and mounting bracket.
11. Use a puller to remove bearing from rotor shaft assembly.
12. Loosen actuator set screw and remove speed sensor actuator. Use a puller if necessary. Speed sensor actuator will not be reused.
13. Press bearing on rotor shaft assembly.
14. Use masking tape or other means to identify leads connected to FR™ activator before removing leads.

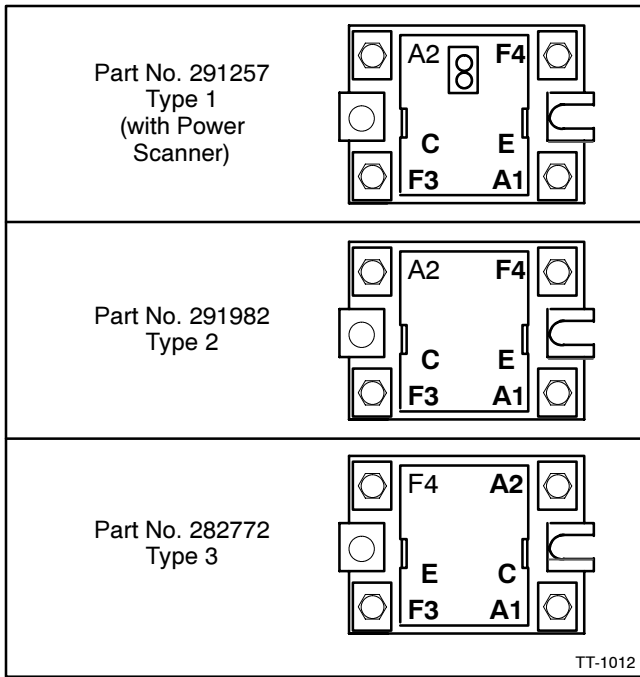
Remove leads C and E of photo transistor board from the FR™ activator. Cut cable ties as necessary to remove leads. Pull lead from rotor shaft assembly and discard.

**Note:** Terminals E and C were reversed on earlier versions of the FR™ activator. See Figure 2.

15. Use masking tape or other means to identify leads connected to FR™ activator before removing leads.

Disconnect main field leads F3 and F4 from FR™ activator. Disconnect exciter armature leads A1 and A2 from FR™ activator. Use care to prevent dropping hardware inside generator set.

**Note:** Terminals F4 and A2 were reversed on earlier versions of the FR™ activator. See Figure 2. Connect leads to terminal with the same terminal designation regardless of the terminal position.



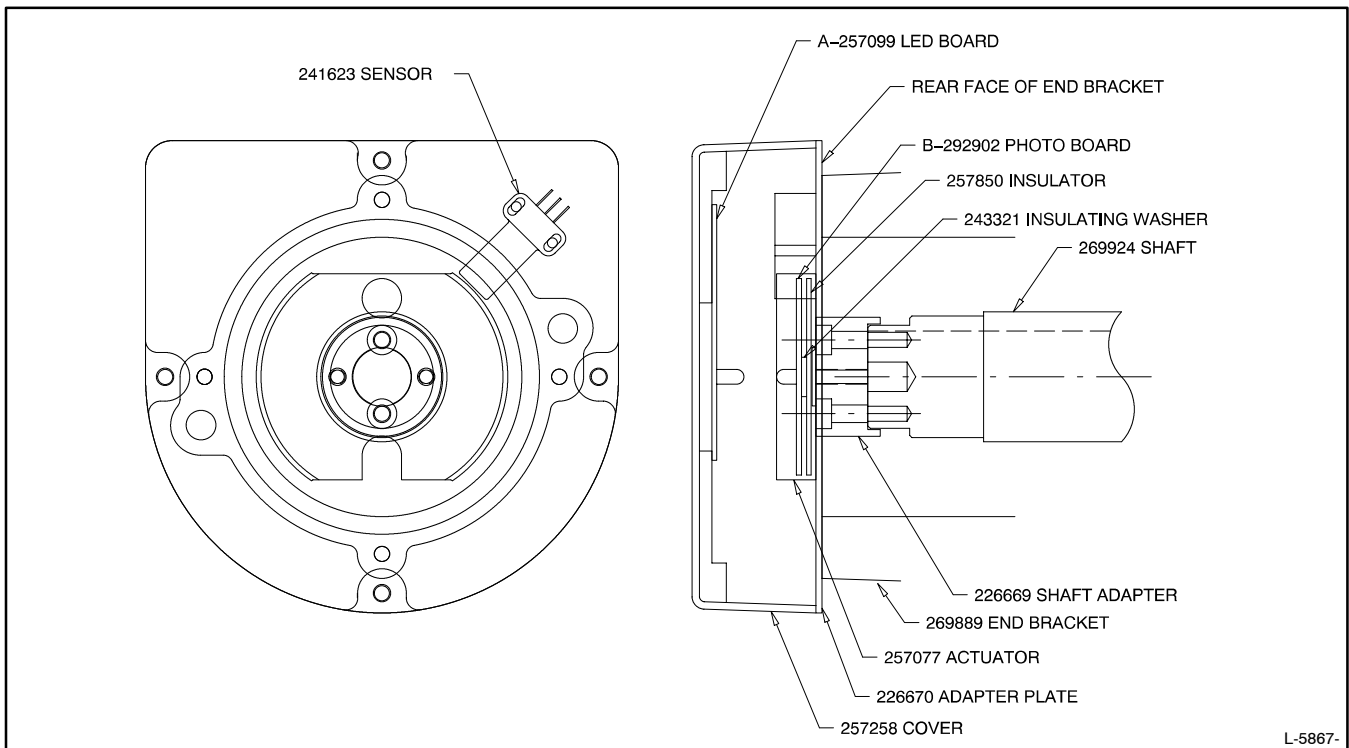
**Figure 2** FR™ Activator Variations

16. Before removing FR™ activator compare terminals with new SCR assembly. The leads may not reach SCR assembly terminals if mounted incorrectly. See Figure 2 for variations of the FR™ activator.

If the old FR™ activator is part no. 282772, position the SCR assembly terminals F- and F+ to correspond with terminals F4 and F3 of the FR™ activator.

If the old FR™ activator is part no. 291982 or 291257, the SCR assembly terminals F- and F+ correspond with F3 and F4 of the FR™ activator. Position and mount SCR assembly so that leads will reach designated terminals.

17. Remove mounting screws and FR™ activator from heat sink assembly. Save screws for installation of new SCR assembly. Original FR™ activator will not be reused. Clean old thermal compound if present from mounting surfaces. New SCR assembly does not require thermal compound.
18. Install SCR assembly (A-226654) in position of old FR™ activator using original screws.
19. Remove terminals from main field leads and exciter armature leads. Cut terminals without removing any more of the lead than necessary. Strip 6 mm (1/4 in.) of insulation from each lead and crimp on four 10-12 ga. eyelet terminals (X-283-22). The leads are connected to SCR assembly later in this procedure.
20. Position end bracket on bearing and use screws connecting end bracket to stator assembly to guide end bracket over bearing. Use original hardware to attach end bracket.
21. Mount adapter shaft (226669) to rotor shaft using two socket head screws (X-55-38). See Figure 3.



**Figure 3** 30 kW Adapter Components

22. Route the photo transistor board lead through hole in rotor shaft and then through exciter laminations to exit near the SCR assembly prior to fastening the photo transistor board to the shaft.
23. Attach photo transistor board (GM34505), two insulating washers (243321), insulator board (257850), and speed sensor actuator (257077) to end of rotor shaft using two screws (X-117-7) and flat washers (X-22-9). Torque to 1.1 Nm (10 in. lb.) maximum. See Figure 3 for component sequence.
24. Cut off excess lead wire from photo transistor board leaving enough wire to reach the SCR assembly and allowing ample working length to attach terminals. Strip 50–75 mm (2–3 in.) of gray insulator jacket from lead. Strip 6 mm (1/4 in.) of insulation off each lead and crimp on four 16–22 ga. eyelet terminals (X-283-7). Secure leads to rotor shaft with cable tie (X-468-3).
25. Make electrical connections to SCR assembly. When there is a choice between which lead to connect, choose the lead which does not stress the lead or terminal. See Figure 4 for wiring schematic.

Connect one main field lead F3 or F4 to F+ stud and connect the other main field lead to F- stud. Connect photo transistor board red lead to F+ stud. Secure with one nut (X-6234-3) on each stud.

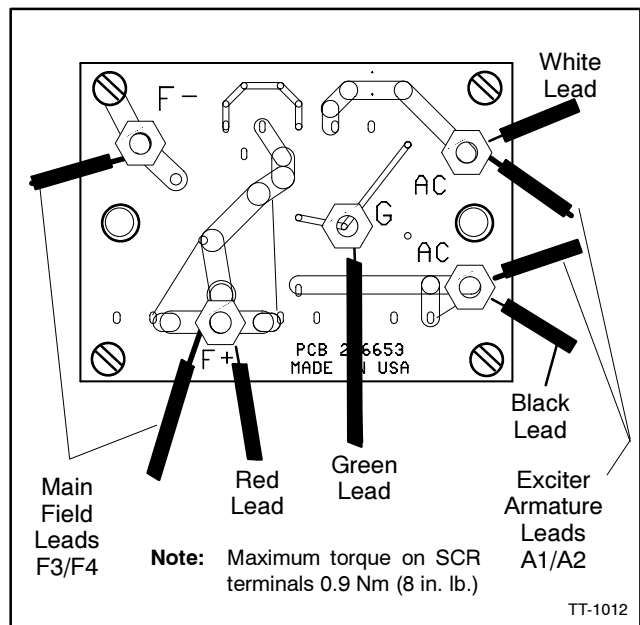
Connect exciter armature leads A1 and A2 to either AC stud. Connect photo transistor board white lead to upper AC stud and black lead to lower AC stud. Secure with one nut (X-6234-3) on each stud. Connect photo transistor board green lead to G stud and secure to stud with one nut (X-6234-3).

**Note:** Green lead and G stud are not ground connections.

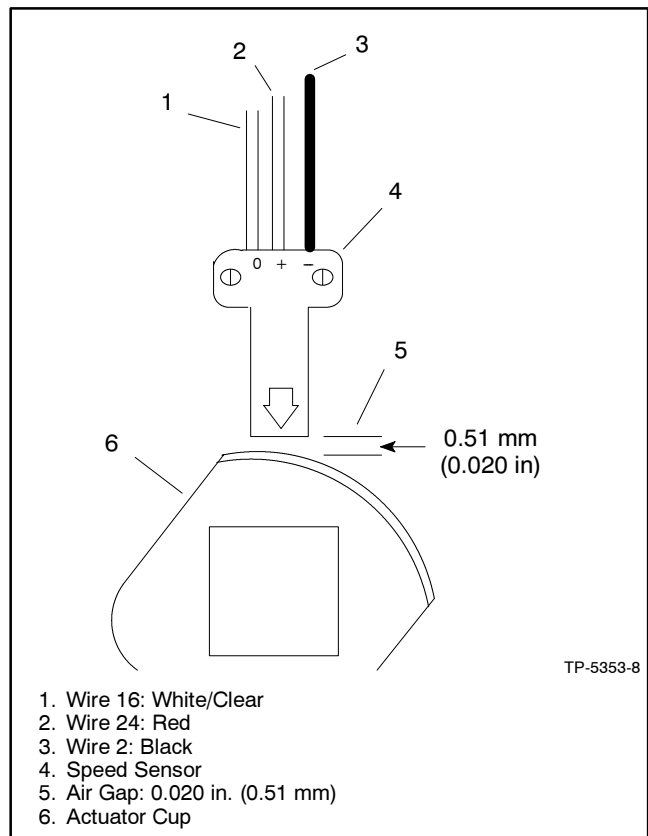
**Note:** Place one elastic stop nut (X-101-24) on each stud. Torque all nuts to 0.9 Nm (8 in. lb.) maximum. Lead terminals must not contact any circuit board solder connections or any other studs or terminals when SCR assembly stud nuts are tightened. See Figure 4 for recommended lead positions. Use cable ties (X-468-3) as necessary to secure leads.

26. Install adapter plate (226670) to end bracket using four screws from original LED board mounting.
27. Insert speed sensor leads through grommet (257069) and reconnect speed sensor leads to original speed sensor. See Figure 5. Temporarily

locate grommet near speed sensor. Mount original speed sensor to adapter plate using two screws (X-49-35), flat washers (X-25-46), and nuts (X-74-6). Set speed sensor air gap to 0.5 mm (0.020 in.). Secure speed sensor leads with cable ties as required.



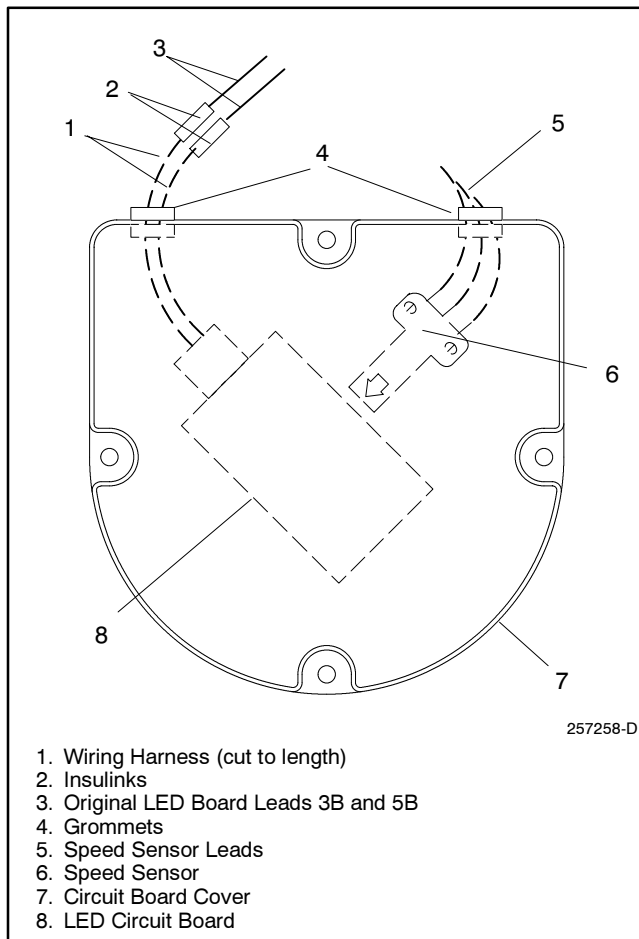
**Figure 4** SCR Assembly Wiring



**Figure 5** Speed Sensor Air Gap

**Note:** If speed sensor leads are too short to reach speed sensor in new location, cut off terminals and add additional lead lengths and insulinks (not supplied). Keep lead lengths as short as possible. Strip 6 mm (1/4 in.) of insulation off each lead and crimp on three 0.11 in. female push-on terminals (X-431-28).

28. Mount new LED circuit board (A-257099) to circuit board cover (257258) using four screws (X-6071-1).
29. Cut connector off of original LED circuit board wiring harness (leads 3B and 5B). If there are leads other than 3B and 5B in original wiring harness these leads will not be used—tape to insulate lead ends. Place grommet (257069) over wiring harness (226672). Attach wiring harness connector to LED circuit board. Place circuit board cover in approximate final installation position and cut wiring harness leads to length. Attach wiring harness to leads 3B and 5B using insulinks (not supplied). Locate grommet in circuit board cover left-side slot. See Figure 6.



**Figure 6** Circuit Board Cover

30. Position grommet of speed sensor leads in circuit board cover right-side slot. Mount circuit board cover to adapter plate using four flat washers (X-25-115) and nuts (X-70-11).
31. Assemble junction box and controller. Reconnect all controller harnesses, if removed.
32. Replace generator end cover and junction box doors.
33. Check that generator set master switch is in the OFF position.
34. Reconnect generator set engine starting battery, negative (-) lead last.
35. Reconnect power to battery charger, if equipped.
36. Start generator set and observe output voltage. Adjust voltage as required using procedure given in generator service manual. Stop generator set when adjustment is complete.

## 40-100 kW Model Installation

1. Place generator set master switch in the OFF position.
2. Disconnect power to battery charger, if equipped.
3. Disconnect generator set engine starting battery(ies), negative (-) lead first.
4. Remove generator end cover and junction box doors.
 

**Note:** If additional clearance is required, disconnect all controller harnesses and remove junction box and controller. These units can be removed as a unit and placed beside the alternator assembly.
5. Remove LED board by removing four screws. Disconnect speed sensor wiring connector.
6. Remove screws securing photo transistor board. Discard original photo transistor board screws.
7. Use masking tape or other means to identify leads connected to FR™ activator before removing leads.

Remove leads C and E of photo transistor board from the FR™ activator. Cut push-on terminals from end of leads and remove photo transistor board. Cut cable ties as necessary to remove leads. Discard original photo transistor board.

**Note:** Terminals E and C were reversed on earlier versions of the FR™ activator. See Figure 7.

- Use masking tape or other means to identify leads connected to FR™ activator before removing leads.

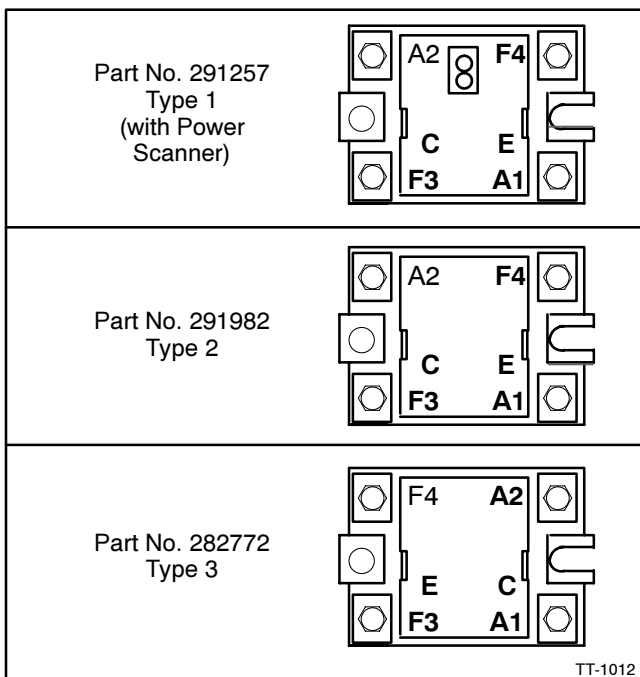
Disconnect main field leads F3 and F4 from FR™ activator. Disconnect exciter armature leads A1 and A2 from FR™ activator. Use care to prevent dropping hardware inside generator set.

**Note:** Earlier versions of the FR™ activator had terminals F4 and A2 reversed. See Figure 7. Connect leads to terminal with the same terminal designation regardless of the terminal position.

- Before removing FR™ activator compare terminals with new SCR assembly. The leads may not reach SCR assembly terminals if mounted incorrectly. See Figure 7 for variations of the FR™ activator.

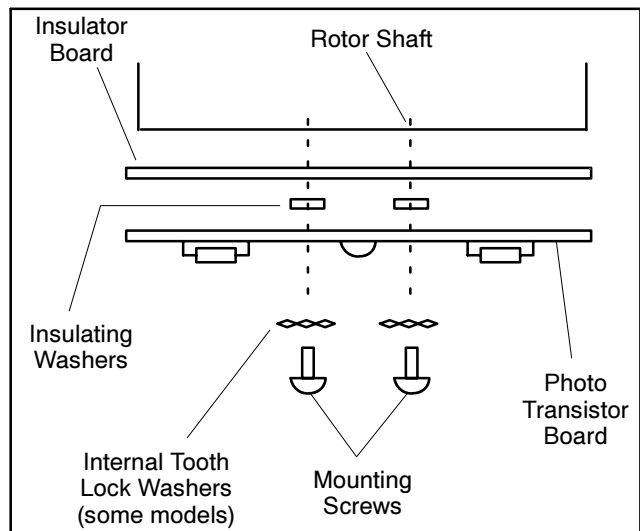
If the old FR™ activator is part no. 282772, position the SCR assembly terminals F- and F+ to correspond with terminals F4 and F3 of the FR™ activator.

If the old FR™ activator is part no. 291982 or 291257, the SCR assembly terminals F- and F+ correspond with F3 and F4 of the FR™ activator. Position and mount SCR assembly so that leads will reach designated terminals.



**Figure 7** FR™ Activator Variations

- Remove mounting screws and FR™ activator from heat sink assembly. Save screws for installation of new SCR assembly. Discard original FR™ activator. Clean old thermal compound if present from mounting surfaces. New SCR assembly does not require thermal compound.
- Install SCR assembly (A-226654) in position of old FR™ activator using original screws.
- Remove terminals from main field leads and exciter armature leads. Cut terminals without removing any more of the lead than necessary. Strip 6 mm (1/4 in.) of insulation from each lead and crimp on four 10-12 ga. eyelet terminals (X-283-22).
- Route the photo transistor board lead through hole in rotor shaft and then through exciter laminations to exit near the SCR assembly.
- Attach photo transistor board (GM34505), two insulating washers (243321), and insulator board (257850) to end of rotor shaft using two screws (X-117-5) and washers (X-22-9). Torque to 1.1 Nm (10 in. lb.) maximum. See Figure 8 for component sequence.
- Cut off excess lead wire from photo transistor board leaving enough wire to reach the SCR assembly and allowing ample working length to attach terminals. Strip 50-75 mm (2-3 in.) of gray insulator jacket from lead. Strip 6 mm (1/4 in.) of insulation off each lead and crimp on four 16-22 ga. eyelet terminals (X-283-7). Secure leads to rotor shaft with cable tie (X-468-3).



**Figure 8** Photo Transistor Board Mounting

16. Make electrical connections to SCR assembly. When there is a choice between which lead to connect, choose the lead which does not stress the lead or terminal. See Figure 9 for wiring schematic.

Connect one main field lead F3 or F4 to F+ stud and connect the other main field lead to F- stud. Connect photo transistor board red lead to F+ stud. Secure with one nut (X-6234-3) on each stud.

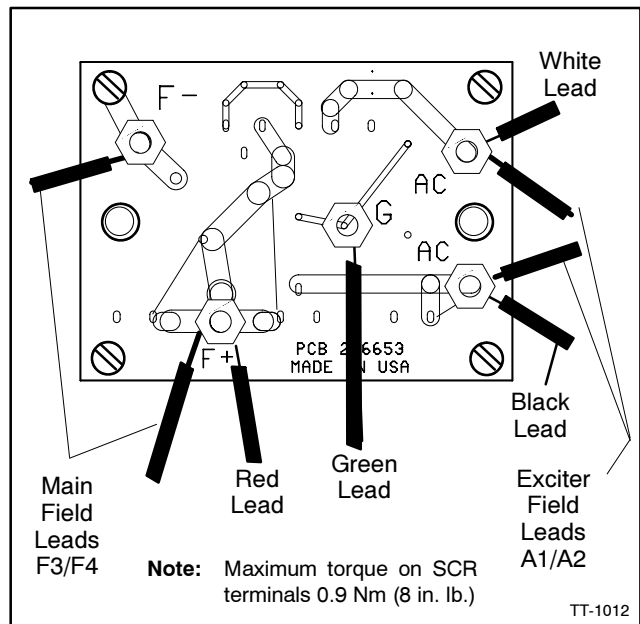
Connect exciter armature leads A1 and A2 to either AC stud. Connect photo transistor board white lead to upper AC stud and black lead to lower AC stud. Secure with one nut (X-6234-3) on each stud.

Connect photo transistor board green lead to G stud and secure to stud with one nut (X-6234-3).

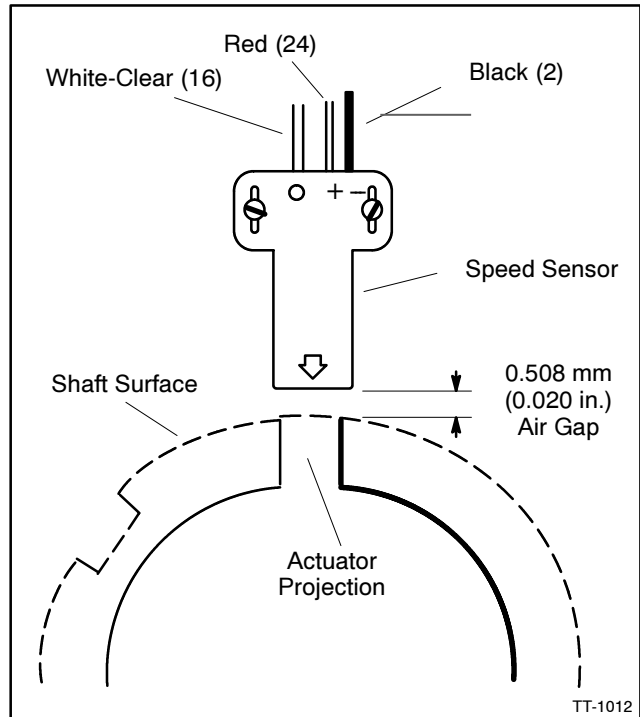
**Note:** Green lead and G stud are not ground connections.

**Note:** Place one elastic stop nut (X-101-24) on each stud. Torque all nuts to 0.9 Nm (8 in. lb.) maximum. Lead terminals must not contact any circuit board solder connections or any other studs or terminals when SCR assembly stud nuts are tightened. See Figure 9 for recommended lead positions. Use cable ties (X-468-3) as necessary to secure leads.

17. Replace LED board using four screws.
18. Reconnect speed sensor leads. Set speed sensor air gap to 0.5 mm (0.020 in.). See Figure 10.
19. Reconnect all controller harnesses and assemble junction box and controller, if removed. Replace generator end cover and junction box doors.
20. Check that generator set master switch is in the OFF position.
21. Reconnect generator set engine starting battery, negative (-) lead last.
22. Reconnect power to battery charger, if equipped.
23. Start generator set and observe output voltage. Adjust voltage as required using procedure given in generator service manual. Stop generator set when adjustment is complete.



**Figure 9** SCR Assembly Wiring



**Figure 10** Speed Sensor Air Gap

## 125-275 kW Model Installation

1. Place generator set master switch in the OFF position.
2. Disconnect power to battery charger, if equipped.
3. Disconnect generator set engine starting battery(ies), negative (-) lead first.
4. Remove generator end cover and junction box doors.
 

**Note:** If additional clearance is required, disconnect all controller harnesses and remove junction box and controller. These units can be removed as a group and placed beside of the alternator assembly.
5. Remove LED board by removing four screws. Disconnect speed sensor wiring harness connector.
6. Remove bearing outer retainer by removing four screws and nuts.
7. Remove screws securing photo transistor board. Photo transistor board screws will be reused.
8. Use masking tape or other means to identify leads connected to FR™ activator before removing leads.

Remove leads C and E of photo transistor board from the FR™ activator. Cut push-on terminals from end of leads and remove photo transistor board. Cut cable ties as necessary to remove leads. Discard original photo transistor board.

**Note:** Terminals E and C were reversed on earlier versions of the FR™ activator. See Figure 11.

9. Use masking tape or other means to identify leads connected to FR™ activator before removing leads.

Disconnect main field leads F3 and F4 from FR™ activator. Disconnect exciter armature leads A1 and A2 from FR™ activator. Use care to prevent dropping hardware inside generator set.

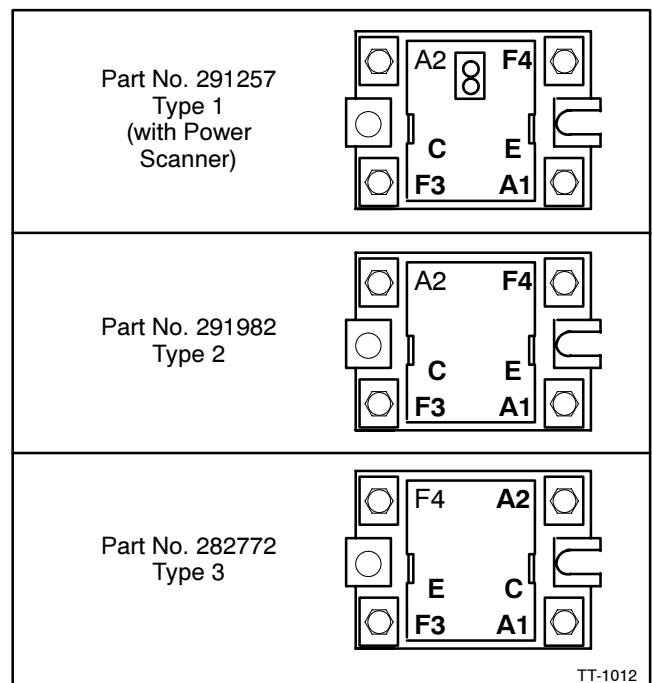
**Note:** Earlier versions of the FR™ activator had terminals F4 and A2 reversed. See Figure 11. Connect leads to terminal with the same terminal designation regardless of the terminal position.

10. Before removing FR™ activator compare terminals with new SCR assembly. The leads may not reach SCR assembly terminals if mounted incorrectly. See Figure 11 for variations of the FR™ activator.

If the old FR™ activator is part no. 282772, position the SCR assembly terminals F- and F+ to correspond with terminals F4 and F3 of the FR™ activator.

If the old FR™ activator is part no. 291982 or 291257, the SCR assembly terminals F- and F+ correspond with F3 and F4 of the FR™ activator. Position and mount SCR assembly so that leads will reach designated terminals.

11. Remove mounting screws and FR™ activator from heat sink assembly. Save screws for installation of new SCR assembly. Discard original FR™ activator. Clean old thermal compound if present from mounting surfaces. New SCR assembly does not require thermal compound.
12. Install SCR assembly (A-226654) in position of old FR™ activator using original screws.
13. Remove terminals from main field leads and exciter armature leads. Cut terminals without removing any more of the lead than necessary. Strip 6 mm (1/4 in.) of insulation from each lead and crimp on four 10-12 ga. eyelet terminals (X-283-22).



**Figure 11** FR™ Activator Variations



14. Route the photo transistor board lead through hole in rotor shaft and then through exciter laminations to exit near the SCR assembly.
15. Mount adapter plate (226671) to rotor shaft using original photo transistor board screws.
16. Attach photo transistor board (GM34505) and two spacers (X-712-19) to adapter plate studs using two washers (X-22-9) and nuts (X-70-11). Torque to 1.1 Nm (10 in. lb.) maximum. See Figure 12 for component sequence.
17. Cut off excess lead wire from photo transistor board leaving enough wire to reach the SCR assembly and allowing ample working length to attach terminals. Strip 50-75 mm (2-3 in.) of gray insulator jacket from lead. Strip 6 mm (1/4 in.) of insulation off each lead and crimp on four 16-22 ga. eyelet terminals (X-283-7). Secure leads to rotor shaft with cable tie (X-468-3) before connecting leads to SCR assembly,
18. Make electrical connections to SCR assembly.

When there is a choice between which lead to connect, choose the lead which does not stress the lead or terminal. See Figure 13 for wiring schematic.

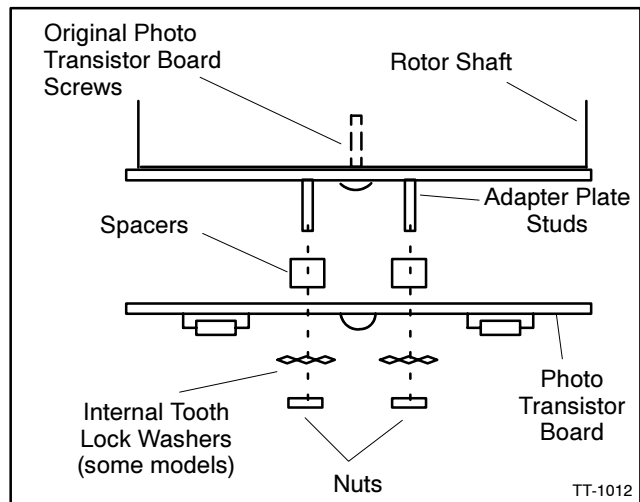
Connect one main field lead F3 or F4 to F+ stud and connect the other main field lead to F- stud. Connect photo transistor board red lead to F+ stud. Secure with one nut (X-6234-3) on each stud.

Connect exciter armature leads A1 and A2 to either AC studs. Connect photo transistor board white lead to upper AC stud and black lead to lower AC stud. Secure with one nut (X-6234-3) on each stud.

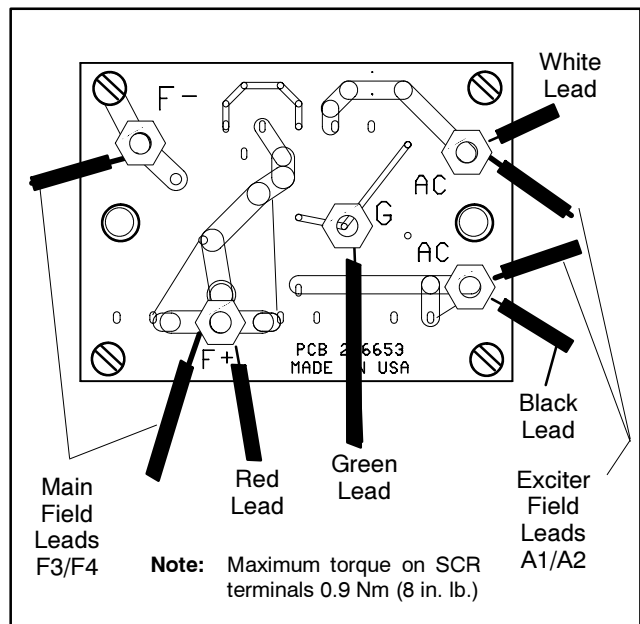
Connect photo transistor board green lead to G stud and secure to stud with one nut (X-6234-3).

**Note:** Place one elastic stop nut (X-101-24) on each stud. Torque all nuts to 0.9 Nm (8 in. lb.) maximum. Lead terminals must not contact any circuit board solder connections or any other studs or terminals when SCR assembly stud nuts are tightened. See Figure 13 for recommended lead positions. Use cable ties (X-468-3) as necessary to secure leads.

19. Install bearing outer retainer using four screws and nuts.
20. Replace LED board using the original screws. Use the four spacers (X-712-19) if necessary to prevent contact between rotating photo transistor board and the stationary LED circuit board. Place the spacers between the LED board and bearing outer retainer.

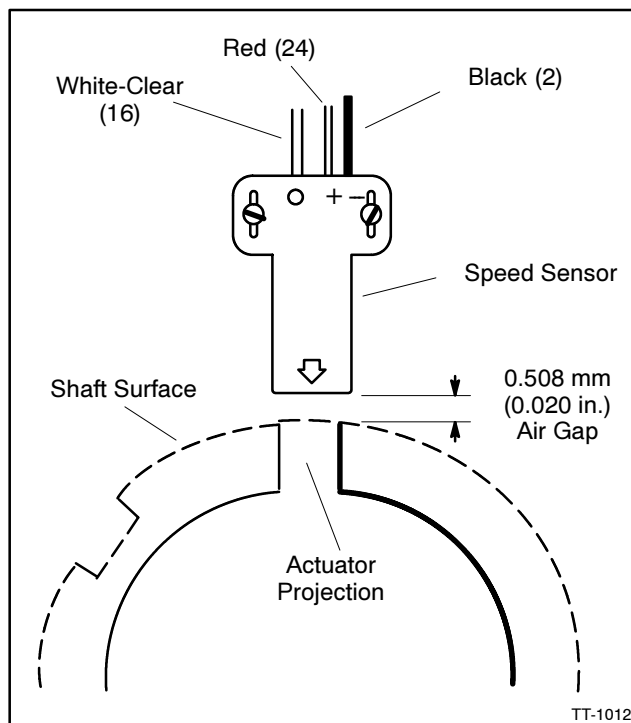


**Figure 12** Photo Transistor Board Mounting



**Figure 13** SCR Assembly Wiring

21. Reconnect speed sensor leads. Set speed sensor air gap to 0.5 mm (0.020 in.). See Figure 14.
22. Reconnect all controller harnesses and assemble junction box and controller, if removed. Replace generator end cover and junction box doors.
23. Check that generator set master switch is in the OFF position.
24. Reconnect generator set engine starting battery, negative (-) lead last.
25. Reconnect power to battery charger, if equipped.
26. Start generator set and observe output voltage. Adjust voltage as required using procedure given in generator service manual. Stop generator set when adjustment is complete.



**Figure 14** Speed Sensor Air Gap

## Parts List

Kits: 226655, 226673, and 226674					
Qty.	Description	Common Parts	Unique Parts		
			30 kW, Kit 226673	40-100 kW, Kit 226655	125-275 kW, Kit 226674
1	Board assy., photo transistor	GM34505	X	X	X
1	Board assy., LED circuit	A-257099	X		
1	SCR assembly	A-226654	X	X	X
5	Nut, 6-32 elastic stop	X-101-24	X	X	X
2	Screw, 10-32 x (photo transistor board)	X-117-5	X	X	
2	Washer, #10 flat (photo transistor board)	X-22-9	X	X	X
2	Washer, #4 flat (speed sensor)	X-25-46	X		
4	Washer, #10 flat (circuit board cover)	X-25-115	X		
4	Terminal, eyelet 10-12 gauge	X-283-22	X	X	X
4	Terminal, eyelet 16-22 gauge	X-283-7	X	X	X
3	Terminals, 3/16 in. F push-on	X-431-28	X		
4	Tie, cable	X-468-3	X	X	X
2	Screw, 4-40 (speed sensor)	X-49-35	X		
2	Screw, 10-24 x 7/8 socket head	X-55-38	X		
4	Screw, 10 x 3/8 thread forming	X-6071-1	X		
5	Nut, 6-32	X-6234-3	X	X	X
4	Nut, 10-32 (circuit board cover)	X-70-11	X		
2	Nut, 10-32 (photo transistor board)	X-70-11			X
6	Spacers (LED board)	X-712-19			X
2	Nut, 4-40 (speed sensor)	X-74-6	X		
1	Shaft, adapter	226669	X		
1	Plate, adapter	226670	X		
1	Plate, adapter	226671			X
1	Harness, wiring	226672	X		
2	Washer, insulating	243321	X	X	
2	Grommets	257069	X		
1	Actuator, speed sensor	257077	X		
1	Cover, circuit board	257258	X		
1	Insulator board	257850	X	X	